

# 卡文汽车VAN产品简介

## CAVAN Product Van Series

2025年6月  
Jun. 2025



卡文汽车专项打造，新能源专属VAN产品平台  
Special platform for new energy VAN  
products developed by CAVAN



## 突破产品边界 车身随需拓展

Break the product boundary Vehicle body can be expanded as demand

从短轴到长轴  
from short axle to long axle

从低顶到高顶  
from low roof to high roof

从货运到客运  
from cargo to passenger  
transport



从有人到无人  
from driver to driverless

从左舵到右舵  
from left-hand drive to right-  
hand drive

从VAN到微卡再到皮卡  
from VAN, to mini truck to  
Pickup

## 精准高效 开放生长的纯电专属底盘

Precise and efficient battery electric chassis

### 精准控制

precise control

- ✓ 高转向精度
- ✓ 快制动响应
- ✓ High steer precision
- ✓ Fast braking response

### 系统高效

efficient system

- ✓ 高集成
- ✓ 低能耗
- ✓ High integration
- ✓ Low energy consumption

### 模块化

modular design

- ✓ 车架模块化
- ✓ 标准接口
- ✓ Modular frame
- ✓ Standard interface

### 可进化

expandable

- ✓ 智能底盘
- ✓ 可迭代
- ✓ Intelligent chassis
- ✓ Iterative

### 电控底盘

Electric control chassis



### 线控底盘

Chassis by wire



# 平台特点 Platform Features

## 正向定义的中央集中电子电气架构 Centralized electronic and electric E/E architecture by forward defining

正向定义 可统一管理  
forward defining unified  
management

- ↓50%控制器数量、↓30%品类
- 6个月开发周期，通讯、电气接口标准化
- ↓90%开发成本
- ↓20%线束降重
- 低压系统免维护，电气系统数字化管理
- ↓50% controller quantity, ↓30% category
- 6-month development cycle, standardized communication and electric interface
- ↓90% development cost
- ↓20% wiring harness weight
- Low-voltage system maintenance free, digital management of electric system

持续进化  
continuous improvement

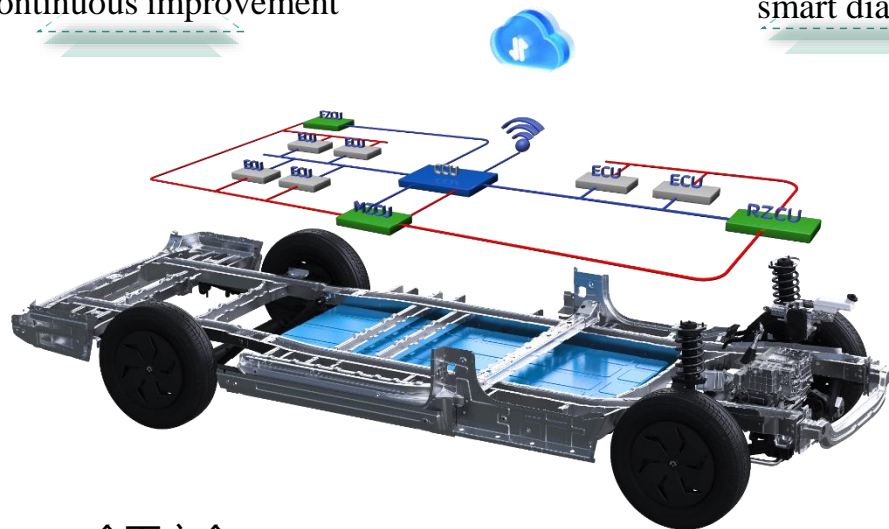

全面安全  
comprehensive safety

智慧诊断  
smart diagnosis

智慧管理  
Smart management

打造多种类算力和软件算法共创  
Co-developed by various hash rates and software algorithm

- 算力支持各级别车控、智驾、座舱
- 新功能开发：1个月
- 边缘计算，毫秒级采集
- 生态应用融合共创
- Hash rates support vehicle control, smart driving and cabins of different levels
- New function development: 1 month
- Edge computing, millisecond collecting
- Ecological application, integrated co-creation

## 高效/强劲/安全的纯电动动力系统 Efficient/strong/safe battery electric power system

### 电池 Battery

极致安全  
Extreme safety

半固态电池  
semi-solid state battery

宽温区适应  
Wide temperature-zone

液冷液热技术  
liquid cooling and heating

快充  
Fast charging

2.2C快充  
2.2C fast charging  
——最快补电6分钟行驶百公里  
6-minute re-charging supports 100km driving

低衰减  
Low decaying

智慧能量管理  
intelligent energy management

商用车首款半固态电池  
The first semi-solid state battery for CV

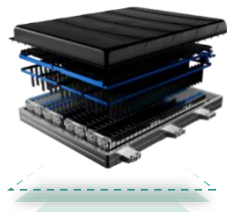

首款定制超薄电池  
The first customized super-thin battery



高效率

High efficiency

系统效率 > 94.5%

system efficiency

### 电驱

Electric drive

强动力

Strong power

动力: ↑40%

Power

多合一电驱动  
Multi-in-one electric drive



# 平台特点 Platform Features

## 智慧的车 强大的云 Smart Vehicle Strong Cloud

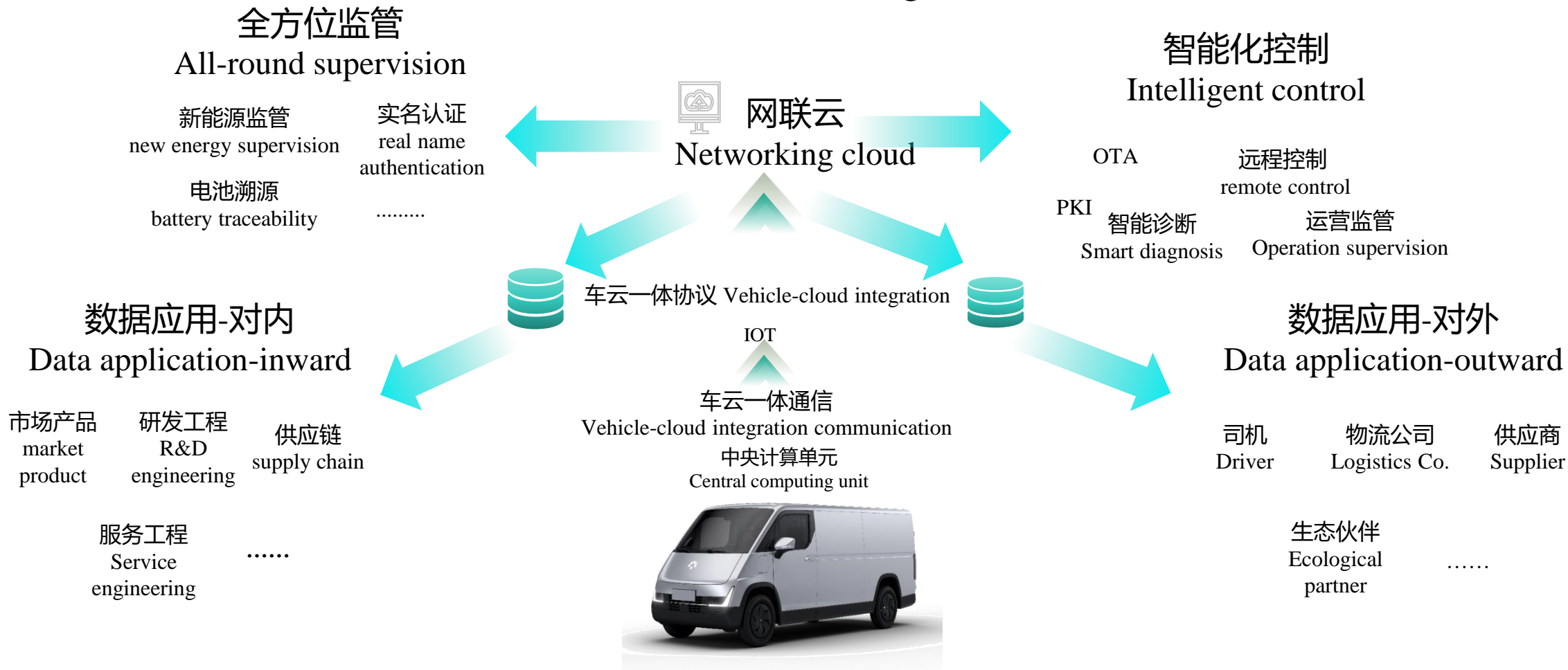

# 产品组合规划 Product Portfolio

卡文乐福海外版产品涵盖7、8、9方货运版，电池采用宁德时代50.23kWh和66.67kWh组合，续航覆盖250-330km范围，其中，左舵产品2025年7月SOP，右舵产品10月SOP。

The overseas cargo-transport version of the Cavan LeFu product includes 7, 8, and 9-cubic variants. Being equipped with CATL battery of 50.23kWh and 66.67kWh, it covers the range of 250-330km. The SOP time for left-hand drive product is July 2025 and for right-hand drive product is October 2025.

7m<sup>3</sup>



8m<sup>3</sup>



9m<sup>3</sup>





长Length/mm	4885	5185	
宽Width/mm	1810		
高Height/mm	1960	1960	2160
总质量GVW/kg	2792	3020	3043
载质量Payload/kg	1000	1200	1200
容积Cargo box volume /m <sup>3</sup>	6.8	7.5	8.5
座位数Seats	3		
驱动型式Drive type	前驱 (FWD)		
驾驶型式Driver's seat	左 (LHD) /右舵 (RHD)		
侧门开启Side door opening	右 (Right) /左右 (Left & Right)		
尾门开启Tailgate	270°对开 ( 270° bi-fold )		
最高车速Top speed (km/h)	120		
电池厂家Battery producer	宁德时代 (CATL)		
电量Battery capacity (kWh)	50.23	50.23/66.67	50.23/66.67
续航里程Range (WLTC/km)	270	258/333	251/325
电机峰值功率及配置Peak Power and Configuration of the Motor	125kW+OBC		

# 乐福产品规划 LeFu Product Planning

## 乐福产品型谱规划 LeFu product portfolio planning

- 乐福产品是基于纯电专属平台打造，车身模块化设计，搭载先进的线控底盘、开源共享的E/E架构、领先的三电及智能化技术，为客户提供便捷、高效、安全的运营保障和智慧的服务及生态。 Special platform for battery electric EV, modular design, advanced chassis-by-wire, open-source sharing E/E architecture, advanced motor, battery and electric control and intelligent technology, which secures the convenient, efficient and safe operation
- 海外版货运产品包含7/8/9方三个容积，其中7方匹配宁德50度电，续航270km，8/9方匹配宁德50/66度电，续航258-325km，电机峰值功率125kW。
- 7/8/9 cubic meters for cargo product, the 7-cubic meter product is equipped with CATL 50kwh, mileage 270km, 8/9-cubic meter products are equipped with CATL 50/66kwh, mileage 258-325km and motor peak power 125kw.

乐福 LeFu	6.8m <sup>3</sup> 短轴 / 平顶 short axle/flat roof		宁德时代 CATL	续航里程 (km) Driving mileage	➔	八合一高效电驱 8-in-1 efficient electric drive	
			电量 (kWh) battery power	WLTC 工况 WLTC working conditions		额定功率/额定扭矩 (kW/N.m) rated power/torque	峰值功率/峰值扭矩 (kW/N.m) peak power/torque
			50.23	270		55/105	125/210
乐福PLUS LeFu PLUS	7.5m <sup>3</sup> 长轴 / 平顶 long axle/flat roof		50.23 66.67	258 333		55/105	125/210
乐福MAX LeFu MAX	8.5m <sup>3</sup> 长轴 / 高顶 long axle/high roof		50.23 66.67	251 325		55/105	125/210

# 乐福产品介绍LeFu Product

## ① 大空间、高承载 Large room, high carrying capacity

多装一成，多1成快乐 More joy by 10% more carrying capacity

### ◆ 极致空间利用率

#### Extreme space utilization rate

- ✓ 大空间：685mm短前悬、500mm超低货台
- ✓ 轻松装：超宽轮距 1250mm
- ✓ 便捷装：侧滑门超大门洞 1100 × 1260 mm，尾门超大门洞 1400 × 1320，大件货物进出自如
- ✓ 8个固定钩-货箱侧围固定
- ✓ large space: 685mm short front suspension, 500mm super low cargo bed
- ✓ large carrying capacity: super wide track 1250mm
- ✓ Convenient loading: side sliding door with the super large door opening 1100 × 1260 mm, tail gate with the super large door opening 1400 × 1320, free in and out for large cargoes
- ✓ 8 fixation hook-cargo box side wall fixing

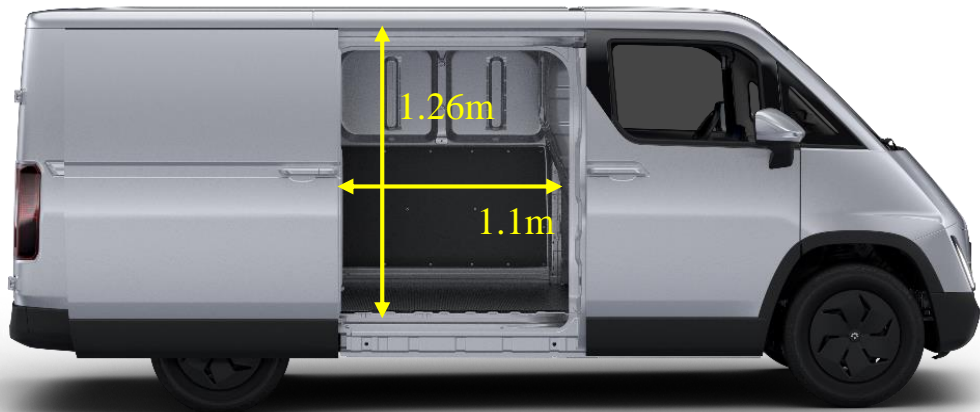

### ◆ 超强承载 1.4T+

#### Super strong carrying capacity 1.4T+

- ✓ 1500Mpa 高强度钢车架、变截面 50CrVA 高强度钢板簧
- ✓ 195/75R16 轮胎同级别车型最大
- ✓ 峰值功率125kW，同级别车型功率最大；峰值扭矩210Nm，扭矩容量超过3800Nm，高出行业平均水平40%
- ✓ 1500Mpa high-tensile frame, taper leaf spring of 50CrVA high-tensile steel
- ✓ 195/75R16 tire is the largest among the peer vehicle models
- ✓ Peak power 125kw, the largest among peer vehicle models; peak torque 210Nm, the torque capacity is over 3800Nm, 40% higher than the average industrial standard

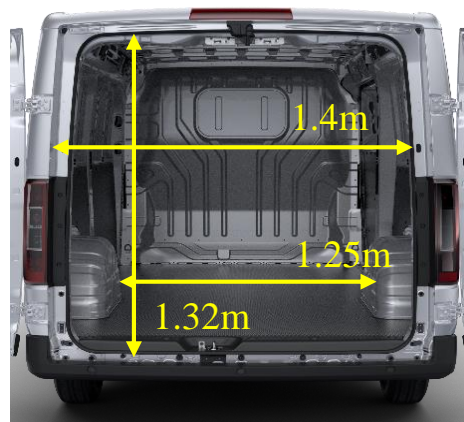

# 乐福产品介绍 LeFu Product

## ② 低能耗、长续航 Low energy consumption, long driving mileage

### 多跑一程，攒1成幸福 Longer driving mileage ensures more savings

- ◆ 风阻系数低至 0.335
- ◆ 同级别电量续航最长，里程覆盖250-330km
- ◆ 行业首创八合一高集成电驱，整车驱动效率 > 93.5%，高效工作区间覆盖 80% 工况
- ◆ 充电 10 分钟，续航 100km
  - ✓ 18min (SOC 20%-80%): 液冷 2C, 行业内领先
  - ✓ 低温充电快, -20°C充电时间缩短 30%
- ◆ Wind resistance coefficient could be as low as 0.335
- ◆ longest driving mileage among peer products, driving mileage covers the range of 250-330km
- ◆ the first 8-in-1 electric drive in the industry, vehicle driving efficiency > 93.5%, efficient working section covers 80% working conditions
- ◆ 10-minute charging enables driving 100km
  - ✓ 18min (SOC 20%-80%): liquid cooling 2C, leading industry standard
  - ✓ fast charging in low temperature, charging duration 30% less under the temperature of -20°C

流线型外观

Streamlined appearance



八合一高效电驱

8-in-1 efficient electric drive

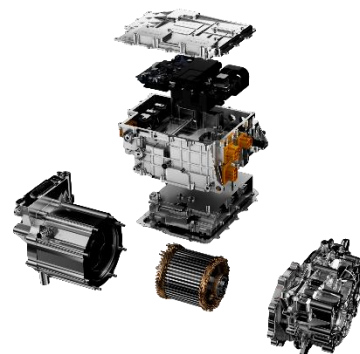

宁德液冷液热电池

CATL liquid cooling and heating battery



# 乐福产品介绍 LeFu Products

## ③ 智能、高效 Intelligent, efficient

### 智行无忧，享1成便捷 Smart driving brings more convenience

- ◆ 智能驾驶+全方位监测，全时守护运营安全
  - ✓ L2+级辅助驾驶，25项智驾配置
- ◆ 三档驾驶模式选择
  - ✓ 三级阶梯能量回收，高效回收能量
- ◆ 数字钥匙，支持无感启动
- ◆ 实现智能管理及智能诊断
- ◆ Smart driving+all-round supervision, all-weather and 24-hour operation safety
  - ✓ L2+class assistant driving, 25 smart driving configurations
- ◆ Three-gear driving mode selection
  - ✓ Three-tire energy collection ensures efficient energy collection
- ◆ Digital key supports senseless start
- ◆ Realize intelligent management and intelligent diagnosis

驾驶模式 可动可静可智能  
driving mode dynamic, stable or intelligent

Eco mode 经济模式	Power mode 动力模式	Auto mode 自适应模式
平滑制动力输出 优化能源管理 城市工况	最大功率释放 响应敏捷 山区工况	驾驶风格智能适应 综合性能平衡 自动调整能量回收 千人千面
smooth braking power output optimize energy management urban working conditions	maximum power release fast response mountainous working conditions	smart adaptation of driving style comprehensive performance balance automatically adjust energy collection customization



智能掌控 智行无忧  
Smart control carefree smart driving

智能管理 intelligent management	智能诊断 intelligent diagnosis
远程控车 车队管理 资产安全 驾驶员监测及行为管理	故障预警 远程诊断 近场诊断 引导诊修
remote control fleet management asset safety driver supervision and action management	fault warning remote diagnosis field diagnosis maintenance guidance



# 乐福产品介绍 LeFu Products

## ④ 多重安全保障 Multiple safety guarantee

### 多重守护，添1成安心

#### Multiple guarantee brings more ease

##### ◆ 车身安全 Vehicle safety

- ✓ 按全球最高标准，欧盟法规要求设计，品质更高、车身更安全
- ✓ 笼式乘员舱设计，1500Mpa 超高强钢，超高强度纵梁+防撞梁+一体式门环
- ✓ design according to the highest standard and EU regulations, high quality and safe vehicle body
- ✓ cage cabin design, 1500Mpa super high-tensile steel, super high-tensile long beam+anti-collision beam+one-piece door ring

##### ◆ 行驶安全 Driving safety

- ✓ 主副驾配备安全气囊、ESC 车身稳定系统、EHB(电子液压制动)、L2+级智能驾驶安全
- ✓ driver's seat and passenger's seat are equipped with airbag, ESC vehicle stability system, EHB (electronic hydraulic braking), L2+ class smart driving safety

笼式乘员舱设计，高强钢占比达63%以上  
cage cabin design, high-tile steel over 63%



国际标准，满足安全要求  
international standard ensures great safety



主副驾安全气囊  
airbags at driver's seat and passenger's seat

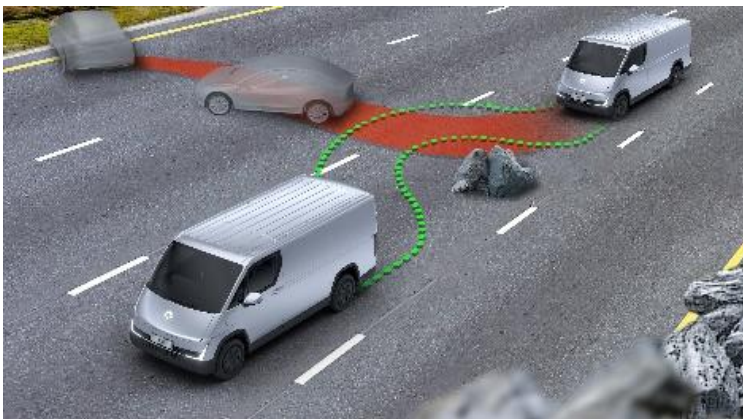

ESC车身稳定系统  
侧翻事故率降70%  
ESC vehicle stability system  
rollover accident rate down by 70%



EHB(电子液压制动) 制动距离缩短9%-16%  
不受高海拔、低气压、长坡道，无衰减  
EHB braking distance down by 9%-16%  
no decay in the high altitude, low voltage, long ramp

# 乐福产品介绍 LeFu Products

## ⑤ 乘用车驾乘感受 Driving experience comparable to passenger vehicle

### 舒享旅程，增1成愉悦 More joy in the pleasant journey

#### ◆ 生态科技内饰，流线型工作台

#### ◆ Ecological technology inner trim, streamlined working station

- ✓ 三幅D型运动方向盘、电子手刹+电子怀挡、自动空调
- ✓ 悬浮式8.8寸液晶屏、12.8寸中控大屏
- ✓ three-spoke D-shape sports steering wheel, electronic hand brake-electronic column shifter, automatic air conditioner
- ✓ floating 8.8-inch LCD, 12.8-inch center control screen

#### ◆ 35项智能座舱功能，360环视，倒车影像，疲劳/分心监测、人脸识别等

#### ◆ 35 smart cabin functions, 360 surround view, reversing image, fatigue monitoring, face recognition

#### ◆ 舒适座椅 Comfort seat

- ✓ 减震调节座椅，弥补货车悬架性能不足，提升舒适性
- ✓ 石墨烯座、背加热，冬天提供更好体感且提供红外理疗功能
- ✓ 4向腰托，满足不同体型人群、不同驾驶阶段的腰部舒适性需求
- ✓ The shock-absorbing adjustable seat makes up the shortage of CV suspension performance, so as to improve comfortability
- ✓ Graphene seat, back heating, better body sensation in winter and infrared physiotherapy function
- ✓ The 4-way lumbar support ensures the waist comfort of people with different sizes and at different driving stages

#### ◆ 转弯半径 5.75m，转弯半径比肩乘用车，三车道一把过

#### ◆ Turning radius 5.75m, comparable to passenger vehicle, only one move for three-lane road

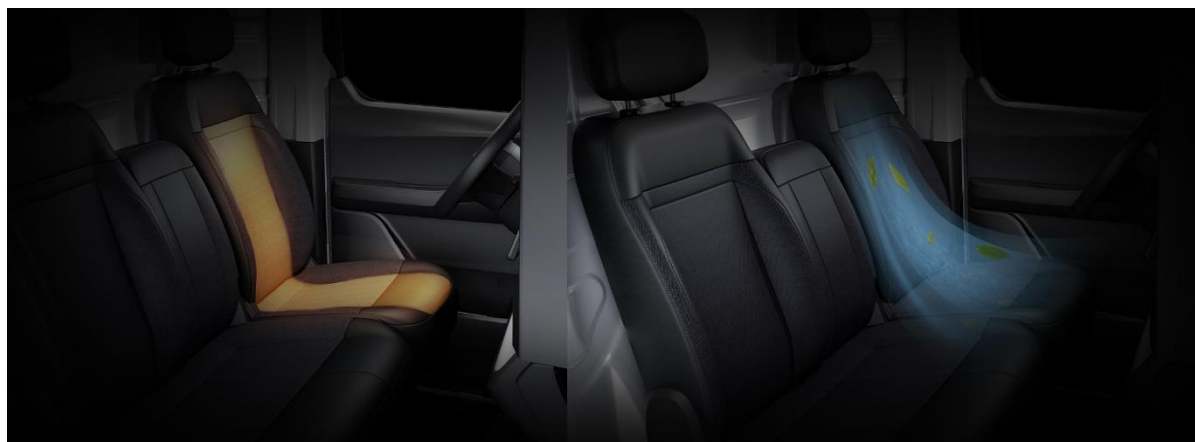



让 每 一 公 里 更 美 好

ONE MILE ONE SMILE

THANKS